

Date: 2006-10-31

ISO/FDIS 18185-7

ISO/TC 104/SC 4

TC 104 Secretariat: ANSI

TC 104/SC 4 Secretariat: DIN

Freight containers – Electronic seals – Part 7: Physical layer

Réceptacles de fret - Joints électroniques - Partie 7: Couche physique

Warning

This document is not an ISO International Standard. It is distributed for review and comment. It is subject to change without notice and may not be referred to as an International Standard.

Recipients of this draft are invited to submit, with their comments, notification of any relevant patent rights of which they are aware and to provide supporting documentation.

Document type: International standard
Document subtype: if applicable
Document stage: (50) Approval
Document language: E

Copyright notice

This ISO document is a working draft or committee draft and is copyright-protected by ISO. While the reproduction of working drafts or committee drafts in any form for use by participants in the ISO standards development process is permitted without prior permission from ISO, neither this document nor any extract from it may be reproduced, stored or transmitted in any form for any other purpose without prior written permission from ISO.

Requests for permission to reproduce this document for the purpose of selling it should be addressed as shown below or to ISO's member body in the country of the requester:

Copyright Manager
ISO Central Secretariat
1 rue de Varembe'
1211 Geneva 20 Switzerland
(V). + 41 22 749 0111
(F) + 41 22 749 0947
(E): iso@iso.ch

Reproduction for sales purposes may be subject to royalty payments or a licensing agreement.

Violators may be prosecuted.

Contents

| | |
|--|----|
| Foreword..... | iv |
| Introduction | v |
| 1 Scope | 1 |
| 2 Normative references | 1 |
| 3 Terms and definitions | 2 |
| 4 Physical layer for electronic seals..... | 2 |
| 4.1 General..... | 2 |
| 4.2 Type A physical layer protocol | 3 |
| 4.3 Type B physical layer protocol | 6 |
| Bibliography | 10 |

Foreword

ISO (the International Organization for Standardization) is a worldwide federation of national standards bodies (ISO member bodies). The work of preparing International Standards is normally carried out through ISO technical committees. Each member body interested in a subject for which a technical committee has been established has the right to be represented on that committee. International organizations, governmental and non-governmental, in liaison with ISO, also take part in the work. ISO collaborates closely with the International Electrotechnical Commission (IEC) on all matters of electrotechnical standardization.

International Standards are drafted in accordance with the rules given in the ISO/IEC Directives, Part 2.

The main task of technical committees is to prepare International Standards. Draft International Standards adopted by the technical committees are circulated to the member bodies for voting. Publication as an International Standard requires approval by at least 75 % of the member bodies casting a vote.

ISO 18185, Part 7 was prepared by Technical Committee 104, Freight Containers, Subcommittee (SC) 4, Identification and communication, Working Group (WG) 2, Automatic Equipment Identification (AEI) for containers and container related equipment.

Attention is drawn to the possibility that some of the elements of this part of ISO 18185 may be the subject of patent rights. ISO shall not be held responsible for identifying any or all such patent rights.

ISO 18185 consists of the following parts, under the general title Freight containers— Electronic seals:

- *Part 1: Communication protocol*
- *Part 2: Application requirements*
- *Part 3: Environmental characteristics*
- *Part 4: Data protection*
- *Part 6: Messages sets for transfer between seal reader and host computer*
- *Part 7: Physical layer*

Introduction

This International Standard was prepared by ISO Technical Committee 104/Subcommittee 4/Working Group 2, using the drafting conventions of ISO/IEC Directives, Part 2.

This standard defines the physical layer for compliant electronic seals.

This standard has been created to ensure global adoption of the standard, providing a standardized physical layer as developed in the RFID standards of ISO/IEC 18000 and 24730.

Freight containers – Electronic seals – Part 7: Physical layer

1 Scope

This International Standard provides the air interface between electronic container seals and reader/interrogators of those seals.

This International Standard shall be used in conjunction with the other Parts of ISO 18185.

This International Standard describes the physical layer for ISO 18185 and ISO 17363 for Supply Chain Applications of RFID for Freight Containers since it is expected that the implementation of these standards will face the same international conditions. However, each of these standards has their own unique requirements other than the physical layer. It is expected that RFID Freight Container Identification (as specified in ISO 10374.2), ISO 17363, and electronic seals, as specified in the suite of standards under ISO 18185, shall be able to use the same infrastructure, while recognizing that there may be requirements for different frequencies for passive devices as opposed to the active devices identified in this standard.

This International Standard applies to all electronic seals used on freight containers covered by International Standards ISO 668, parts 1 to 5 of ISO 1496, ISO 830 and should, wherever appropriate and practicable, be applied to freight containers other than those covered by the aforementioned International Standards;

2 Normative references

The following referenced documents are indispensable for the application of this document. For dated references, only the edition cited applies. For undated references, the latest edition of the referenced document (including any amendments) applies.

ISO/IEC 2382-26, *Information technology - Vocabulary - Part 26: Open systems interconnection*

ISO 17712, *Freight containers – Mechanical seals*

ISO/IEC 18000-7, *Information technology, Automatic Identification and Data Capture techniques – Radio Frequency Identification (RFID) for item management – Air interface Part 7: Parameters for an active RFID air interface communications at 433 MHz*

ISO/IEC 19762, Part 1, *Information technology, Automatic Identification and Data Capture techniques – Harmonized vocabulary – Part 1: General terms relating to Automatic Identification and Data Capture (AIDC)*

ISO/IEC 19762, Part 3, *Information technology, Automatic Identification and Data Capture techniques – Harmonized vocabulary – Part 3: Radio-Frequency Identification (RFID)*

ISO/IEC 24730-2, *Information technology — Automatic Identification and Data Capture techniques - Real Time Locating Systems (RTLS) — Part 2: 2,4 GHz*

3 Terms and definitions

For the purposes of this document, the terms and definitions given in ISO/IEC 19762, Parts 1 and 3, ISO 17712, and the following apply.

3.1

electronic seal

eSeal

read-only, non-reusable freight container seal conforming to the high security seal defined in ISO 17712 and conforming to ISO 18185 or revision thereof that electronically evidences tampering or intrusion through the container doors

3.2

seal identification

seal ID

unique identification of each manufactured seal incorporating serial number (i.e., Tag ID), and manufacturer ID; the combination of which shall be called seal ID.

3.3

interrogator identification

interrogator ID

code used to identify the source address during every communication session originated by the interrogator.

3.4

physical layer

in the Open Systems Interconnection reference model, the layer that provides the mechanical, electrical, functional, and procedural means to establish, maintain and release physical connections for transfer of bits over a transmission medium. [ISO/IEC 2382-26, 26.02.09]

3.5

LF transmitter ID

code used to identify the LF transmitter

4 Physical layer for electronic seals

4.1 General

The 18185 system consists of the three distinct components: eSeal, LF transmitter, and reader. The main feature of the system is its dual frequency operation:

There are two types of physical layers. Type A physical layer is the 433 MHz as long range Link and OOK LF short-range link. Type B physical layer is the 2,4 GHz long rang link and FSK short-range link. The eSeal shall support both types of air interfaces. The data link protocols are different for each physical layer. Interrogators and reader devices may support one or both types of physical layers.

The eSeal shall be capable of communicating on two long-range RF links. The protocol for these two links is specified in sections 4.2.1 and 4.3.1. The e-seal shall also be capable of receiving LF magnetically coupled transmissions as specified in section 4.2.2 and 4.3.2. Data may be transmitted from the LF transmitter to the eSeal(s) without acknowledgment (one-way link only).

Short range, low frequency short-range link between LF transmitter and eSeal(s) is used to localize eSeal(s) inside the magnetically coupled transmitter antenna field of a LF transmitter. Data is transmitted from the LF transmitter to the eSeal(s) without LF acknowledgment. All eSeal(s) in the field of a LF transmitter receive LF transmitter's data simultaneously, i.e. it takes LF transmitter the same amount of time to transmit its data to any number of eSeals.

The long range links (433,92 MHz or 2,4 GHz) are used by eSeal(s) to reply to the Reader with the location (i.e. LF transmitter ID), its own identification (eSeal ID), and eSeal Status data is transmitted from the eSeal(s) to the Reader(s).

To avoid collisions during UHF transmission, in type A operation mode, the eSeal operates according to the anti-collision algorithm specified in section 4.2; in type B operation mode, the eSeals do not require an anti-collision protocol.

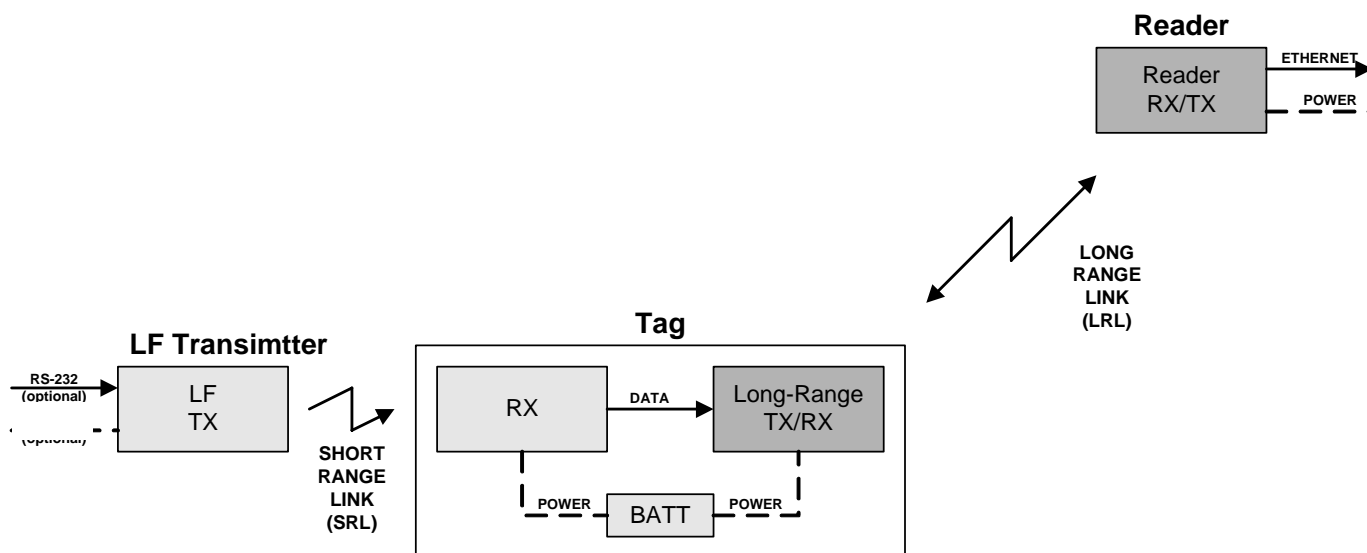

Figure 1 - System components

4.2 Type A physical layer protocol

4.2.1 433 MHz long range link physical layer protocol

The collision arbitration uses a mechanism, which allocates tag transmissions into slots within specified collection round (or so called window size). The Window Size parameter indicates the time an interrogator will listen for tag responses during a current collection round. A collection round consists of a number of slots. Each slot has a duration long enough for the Interrogator to receive a tag response. The actual duration of a slot is determined by the Interrogator collection command type and is a function of the tag transmission time.

The Interrogator initiates a tag collection process by sending a Collection command. Tags receiving a Collection command randomly select a slot in which to respond, but do not immediately start transmitting. The number of slots in a current collection round is determined by the required field size based on the type of Collection command. Each Collection command requires specific type and amount of data to be transmitted by the tag within single slot time. Therefore the size of each slot is determined by the length of time needed for a tag to provide the designated response indicated by the specific command. The number of available slots will be determined by dividing the window size by the time required for an individual tag response. During the subsequent collision arbitration process the Interrogator dynamically chooses an optimum window size for the next collection round based on the number of collisions in the round. The number of collisions is a function of the number of tags present within the Interrogator communication range that participate in the current collection round.

On receiving a Collection command, tags select a slot in which to respond. The selection is determined by a pseudo-random number generator. When a tag selects a slot number it will wait for a pseudo-random time delay equal to a time of slot number multiplied by slot delay before it responds. The number of slots is determined by the current window size, indicated through the Interrogator collection command type and a tag transmission time.

After the Interrogator has sent the Collection command there are three possible outcomes:

- 1) The Interrogator does not receive a response because either no tag has selected current slot or Interrogator did not detect a tag response. Once no tag is detected in any slot, the Interrogator then terminates current collection round. This process will be repeated for 3 rounds before the collection process is terminated.
- 2) The Interrogator detects a collision between two or more tag responses. Collisions may be detected either as contention from the multiple transmissions or by detecting an invalid CRC. The Interrogator records collision and continue, "listening" for a new tag in the subsequent slot.
- 3) The Interrogator receives a tag response without error, i.e. with a valid CRC. The Interrogator records the tag data and continues to listen for a new tag in the subsequent slot.

The collection round continues until all slots within the round have been explored.

When the collection round is completed the Interrogator starts transmitting Sleep command to all tags collected during the previous collection round. The tags that receive Sleep command move to "sleep" mode and will not participate in collection in the subsequent collection rounds.

The interrogator immediately starts the next collection round by transmitting the collection command.

This process continues until no more tags are being detected during three subsequent collection rounds.

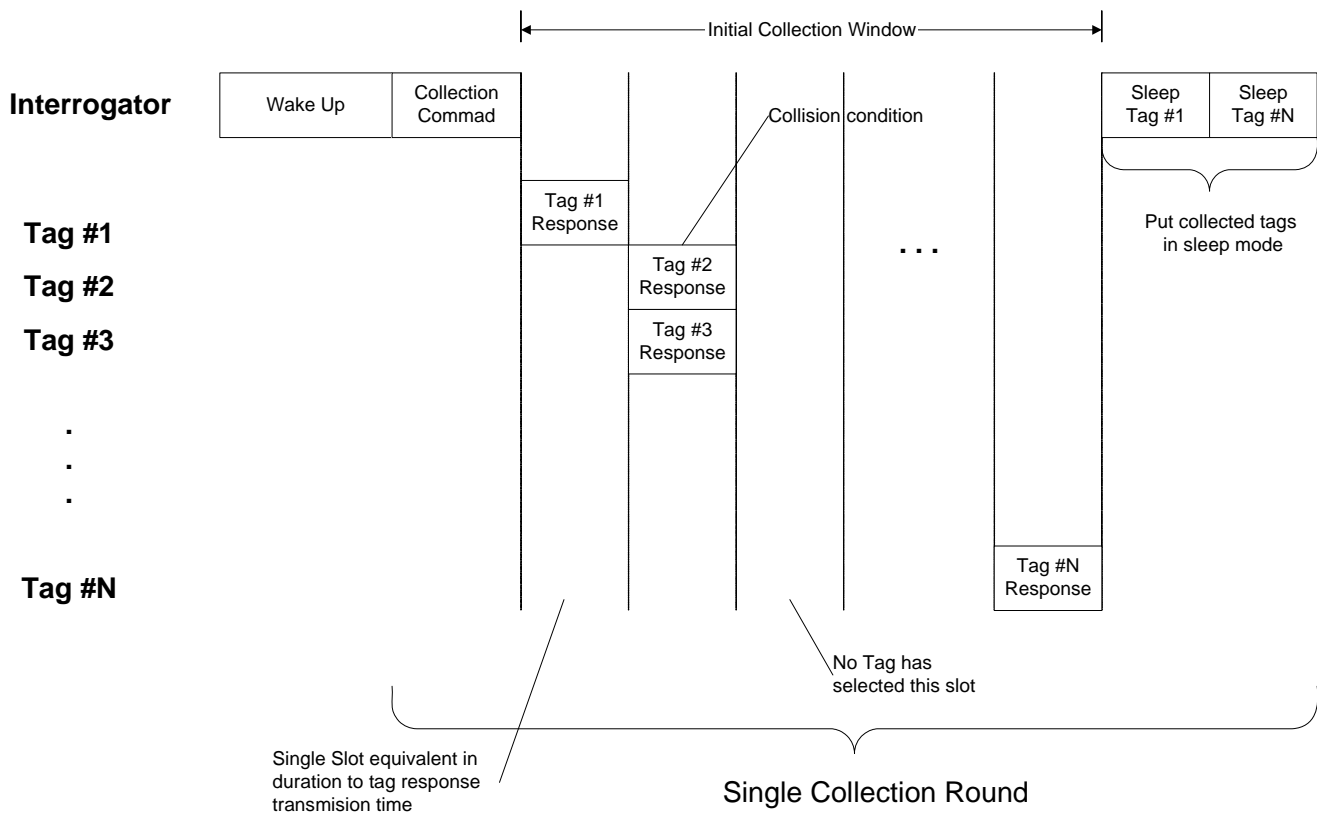

Figure 2 - Collection process example

4.2.1.1 General

ISO 18185-1 defines the communications protocol beyond the physical layer.

4.2.1.2 Compliance to air interface standards

The physical layer of an electronic seal compliant with this standard shall be in accordance with ISO/IEC 18000, Part 7, Clauses 6.1, 6.2.2, 6.2.3, 6.2.5, 6.3.1, and 6.3.2.

4.2.2 OOK LF physical layer protocol

The LF transmitter to eSeal communication utilizes low frequency (123-125 kHz) OOK modulation schemes and operates at short range. Data is repeatedly transmitted (or when triggered by the external sensor) from the LF transmitter to the eSeal without acknowledgment.

4.2.2.1 Data modulation and coding

4.2.2.1.1 Data modulation

Data transmitted between the LF transmitter and the eSeal utilizes OOK.

4.2.2.1.2 Data encoding

Manchester encoding is used for data.

4.2.2.1.3 Data rate

The data rate is approximately 1600 bps.

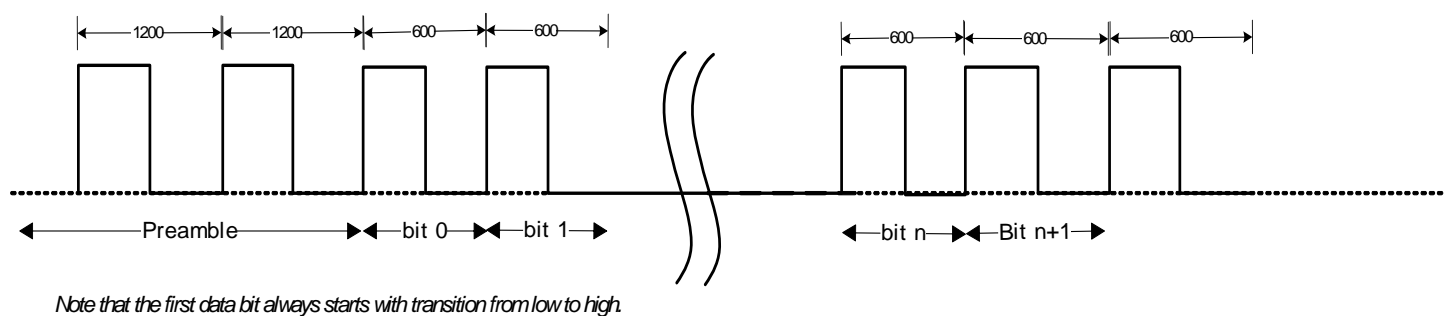

Figure 3 - OOK LF packet structure

As each packet sent from the LF transmitter to the eSeal might have a different length, the start of every packet is indicated by preamble. The end of packet is indicated by a final period of at least 1200 μ s of continuous "off" modulation transmission (i.e. no transmission) for each packet after the CRC bytes.

The preamble is defined as at least eight subsequent pulse intervals of 1200 μ s. If multiple packets are sent one after another, a preamble of at least two 1200 μ s intervals is used between two subsequent packets..

4.3 Type B physical layer protocol

4.3.1 2,4 GHz long range link physical layer protocol

The physical layer for this portion of the 18185 standard shall be as in accordance with clauses 5.5, table 1, and clause 6 of ISO/IEC 24730-2 and, with the exception of the location function of ISO/IEC 24730-2, be completely compatible with that standard.

4.3.2 2,4 GHz physical link parameters

For the purposes of this document, the following parameter definitions apply in Table 1. These parameters are referenced by parameter name. These operating parameters are to be defined for the temperature range of. To be amended with parameters in 18185-3.

Table 1 — eSeal transmitter link parameters

| Parameter name | Description |
|----------------------------------|--|
| Operating frequency range | 2400–2483,50 MHz |
| Operating frequency accuracy | ± 25 ppm maximum |
| Centre frequency | 2441,750 MHz |
| Occupied channel bandwidth | 60 MHz |
| Transmit power | Class 1: 10 dBm EIRP max. Class 2: Maximum in accordance to local regulations. |
| Spurious emission, out of band | The device shall transmit in conformance with spurious emissions requirements defined by the country's regulatory authority within which the system is operated. |
| Modulation | BPSK Direct Sequence Spread Spectrum (DSSS) |
| Data encoding | Differentially encoded |
| Data bit rate | 59,7 kb/s |
| Bit error rate | 0,001% |
| PN chip rate | 30,521875 MHz +/- 25 ppm |
| PN code length | 511 |
| PN spread code | 0x1CB |
| Data packet lengths | 152 bits |
| Message CRC polynomial | $G(x)=X^{12} + X^{11} + X^3 + X^2 + X + 1$ |
| CRC polynomial initialized value | 0x001 |
| Blink interval | Programmable, 5 s minimum |
| Blink interval randomization | ±638 ms maximum |
| Number of sub-blinks | Programmable, 1 - 8 |
| Sub-blink interval randomization | 125 ms ±16 ms maximum |
| Maximum Frequency Drift | < +/- 2 ppm over the duration of the entire message |
| Phase Accuracy | < 0,50 radians within any 33 µs period |
| Phase Noise | < 15 degrees when the noise is integrated from 100 Hz to 100 kHz |

4.3.3 System description

The 2,4 GHz transmitter module in an eSeal is a compact internally powered radio frequency device that is a component of the eSeal system (hereinafter referred to as the transmitter). Each transmission is a pulse of direct sequence spread spectrum radio signal. The reader infrastructure receives these signals, or blinks. The blink is a short ID-only message or a longer telemetry message also containing the transmitter's ID. Each transmission also contains a status data word that provides information on the transmitter configuration, battery status and other data. The transmitter's ID, status data word, and location are provided to the host by the reader Infrastructure. Multiple transmitters may be present in typical installations allowing a large number of items to be tracked and located in real time.

Anti-collision synchronization protocols are not required. Each "blink" is comprised of multiple sub-blinks. The sub-blinks are part of a multiple level anti-interference system; time diversity, spatial diversity, processing gain. The combination of these multiple sub-blinks, multiple receiving antennas and spread spectrum correlation also allow multiple transmitters to blink simultaneously and still be received.

The transmitter data shall be binary encoded with the MSB (Most Significant Bit) transmitted first in all messages. It is differentially encoded using the example circuit of Figure 4. The output of the encoder shall be initialized to "1". It shall be exclusively OR'd with the output of the PN (Pseudo Noise) generator, modulated using a BPSK (Bi-Phase Shift Keyed) format and upconverted using a single sideband upconverter. The signal is then amplified and transmitted to the reader infrastructure.

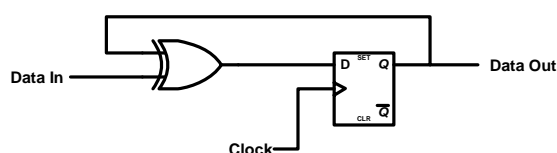

Figure 4 — Example of differential encoding circuit

An example of the eSeal transmitter PN Generator is shown below in Figure 5.

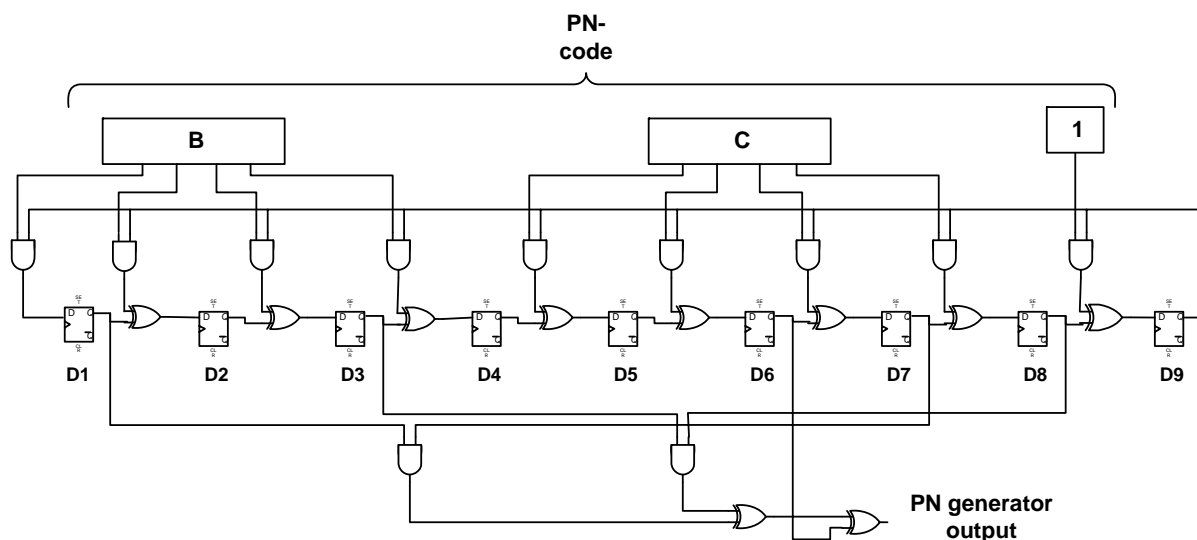

Figure 5 — eSeal transmitter PN generator

Data encoding and transmission process is shown below in Figure 6.

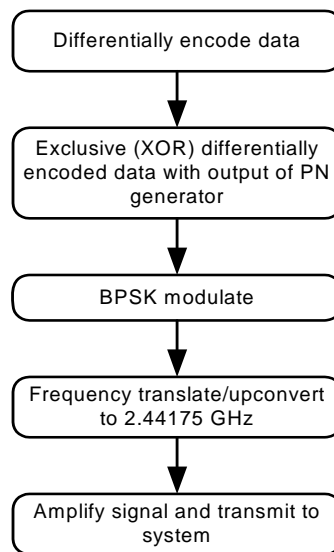

Figure 6 — Transmitter data encoding and transmission process

The format of the Direct Sequence Spread Spectrum (DSSS) transmission from the transmitter is shown in Figure 7. Each DSSS transmission from the transmitter contains a “blink” packet containing N sub-blinks. All sub-blinks within a “blink” shall be identical to provide time diversity. Each sub-blink includes the fields defined in 2,4 GHz protocol specified in 18185-1. The “blink” packet occurs at the beginning of the blink interval. Sub-blinks shall be separated by an interval, which is not user configurable. The number of sub-blinks per blink and the blink interval may be configurable.

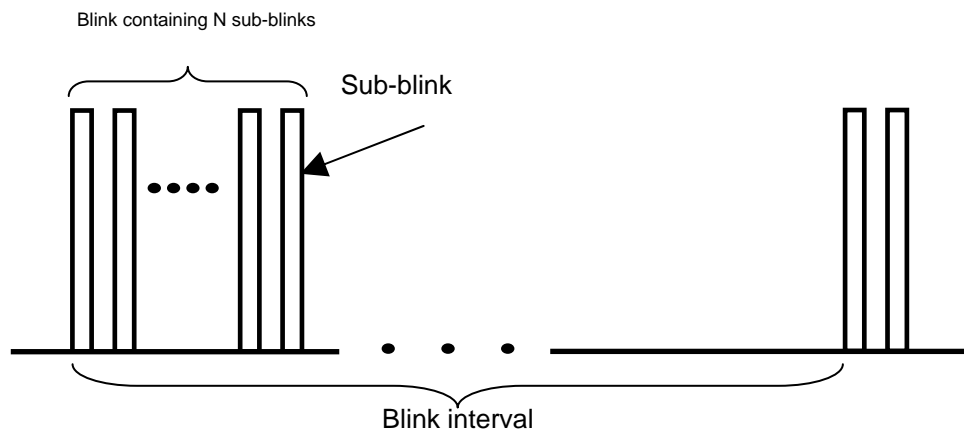

Figure 7 – DSSS air interface

The DSSS carrier frequency is fixed at 2441,75 MHz and the chip rate shall be fixed at 30,521875 MHz.

4.3.3.1 Transmitter radiated power

Two classes of transmitters exist with respect to the output power level they are capable of delivering. The Equivalent Isotropically Radiated Power (EIRP) of a Class 1 transmitter is less than 10 mW (10 dBm). Class 1 transmitters are intended for applications with moderate to dense infrastructures and minimal obstructions.

The EIRP of a Class 2 transmitter is greater than 10 mW (10dBm) and less than the maximum allowed by local radio regulations. Class 2 transmitters are intended for sparse infrastructures where readers may be located greater than 300 meters from the transmitter or environments with major obstructions.

4.3.3.2 DSSS message encoding

The PN Spreading Code shall be 0x1CB. The PN Generator is initialized with a "1" in register D9 and "0"s in all other registers.

The beginning of the blink interval shall be randomized by a maximum of ± 638 ms to avoid repeatedly colliding with blinks from other transmitters. The beginning of each successive sub-blink shall also be randomized. The interval between each sub-blink shall be 125 ms randomized by a maximum of ± 16 ms from the beginning of the previous sub-blink.

4.3.4 FSK short range link physical layer protocol

4.3.4.1 Physical link specifications

Table 2 lists the physical link specifications from the LF transmitter to the eSeal.

Table 2 - Magnetic physical link specifications

| Item | Parameter | Value |
|------|-----------------------|---|
| M 1 | Signaling frequencies | 114,688 kHz and 126,976 kHz |
| M 2 | Field strength | Regulatory / application dependent |
| M 3 | Bit data rate | 2,048 kb/s |
| M 4 | Symbol period | 244,14 μ s |
| M 5 | Data error rate | 0,001% |
| M 6 | Start sync | 3 symbol periods @ 114,688 kHz followed by 3 symbol periods @ 126,976 kHz |
| M 7 | End sync | 3 symbol periods @ 126,976 kHz followed by 3 symbol periods @ 114,688 kHz |
| M 8 | Data bit "0" | 1 symbol period @ 126,976 kHz followed by 1 symbol period @ 114,688 kHz |
| M 9 | Data bit "1" | 1 symbol period @ 114,688 kHz followed by 1 symbol period @ 126,976 kHz |

4.3.4.2 LF transmitter air interface

The LF transmitter is a device that shall repetitively transmit, without gap, 28-bit or 44-bit magnetic messages designed to stimulate responses from RTLS transmitters. The LF Transmitter shall be a transmit-only device and shall not have an air interface receiver. The transmitter configuration shall change to the parameters specified in the 44-bit message.

The LF transmitter shall communicate via a FSK magnetic link. The magnetic FSK frequencies shall be 114,688 kHz and 126,976 kHz. The LF transmitter shall use Manchester Encoding.

Bibliography

- [1] ISO 1496-1, *Series 1 freight containers – Specification and testing – Part 1: General cargo containers for general purposes*
- [2] ISO 1496-2, *Series 1 freight containers – Specification and testing – Part 2: Thermal containers*
- [3] ISO 1496-3, *Series 1 freight containers – Specification and testing – Part 3: Tank containers for liquids, gases and pressurized dry bulk*
- [4] ISO 1496-4, *Series 1 freight containers – Specification and testing – Part 4: Non-pressurized containers for dry bulk*
- [5] ISO 1496-5, *Series 1 freight containers – Specification and testing – Part 5: Platform and platform-based containers*
- [6] ISO 10374.2, *Freight containers – RF for automatic identification (formerly Freight containers - Automatic identification)*
- [7] ISO 17363, *Supply chain applications of RFID – Freight containers*
- [8] European Union, ERC Recommendation 70-03, *Relating to the use of Short Range Devices (SRD), Annex 1 Non-specific Short Range Devices*
- [9] European Union, ETSI EN 300 220, *Radio equipment and systems; short range devices; Technical characteristics and test methods for radio equipment to be used in the 25 MHz to 1000 MHz frequency range with power levels ranging up to 500 mW*
- [10] ANS INCITS 256 Part 4.2, *Radio Frequency Identification (RFID) - UHF RFID Protocols – 433,92 MHz UHF narrowband active tag interface*
- [11] USA, 47 CFR, Part 15, Code of Federal Regulations, Federal Communications Commission, 47 CFR, Part 15 - *Radio frequency devices*